

Product Introduction

GURC01

Ultrasonic Sensing and Signal Processor

1 Product characteristics

■ Memory

- MTP: Nonvolatile memory, 8-bit width, 9Bytes, storing calibration data (OSC calibration data, user-defined data, amplifier gain configuration and other parameters), ID
- Volatile memory: Store register values

■ Clock

- OSC: 12MHz oscillator, supporting user calibration

■ Power supply and power supply management

- V_{SUP} range: 6V~18V
- Support V_{SUP} overvoltage detection and undervoltage detection
- V_{DDD} range: 4.5V~5.5V
- V_{DDA} range: 3.1V~3.5V
- POR threshold: 4.5V
- Support standby mode

■ Sensor driver

- The measurement mode supports the receiving mode and the transmitting mode
- Programmable sensor frequency: 30kHz~83kHz
- Driving current of programmable transformer: 187mA~404mA

■ Receiver

- Front end of receiving analog, including PGA, AAF and ADC
- PGA: Programmable amplifier, with 36~50dB analog amplification
- AAF: Anti-alias filter, with DC gain of 2.3 times, and unit gain bandwidth of 200kHz

- ADC: 12bit, 1MHz sampling rate, significant bit not less than 8bit

■ Signal processor

- Digital filter
- Digital amplifier: Digital amplifier can be configured, supporting sensitivity time control (STC)
- Echo detection: Support static threshold generation, automatic threshold generation (ATG), echo width detection, echo peak detection (EPD), signal enhancement through fast time constant algorithm (FTC), near-field threshold generation (NFTG), and time measurement

■ Communication interface

- 3-wire bidirectional communication interface, flexible communication protocol
- Transmission command and data
- Obtain envelope curve
- Obtain echo detection signal

■ Built-in temperature sensor

■ JTAG debugging interface

■ Application

- Ultrasonic parking assist system (USPA, PAS, etc.)
- Industrial distance measurement

■ Encapsulation type

- QFN20

■ Packaging type

- Tray
- Reel

Contents

1	Product characteristics	1
2	Pin information	3
2.1	Pin distribution	3
2.2	Pin functional description.....	3
3	Functional Description	5
3.1	Overview	5
3.1.1	Principle of ultrasonic distance measurement.....	5
3.1.2	Measurement period.....	5
3.2	System architecture block diagram	7
4	Electrical characteristics	8
4.1	Test conditions of electrical characteristics	8
4.1.1	Maximum and minimum values	8
4.1.2	Typical value.....	8
4.2	Recommended operating conditions.....	8
4.3	Absolute maximum rated value	8
4.3.1	Maximum temperature characteristics	8
4.3.2	Maximum rated voltage characteristics	9
4.3.3	ESD protection	9
4.3.4	Static latch-up.....	10
5	Typical application	11
5.1	Typical application circuit.....	11
6	Reflow soldering profile information	12
7	Package information	13
8	Packaging information	15
8.1	Tray packaging	15
8.2	Reel packaging.....	16
9	Ordering information	18

2 Pin information

2.1 Pin distribution

Figure 1 Distribution Diagram of GURC01 Series QFN20 Pins

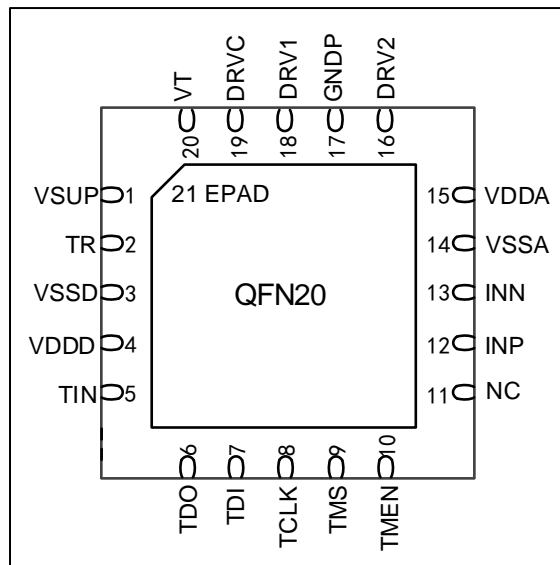

2.2 Pin functional description

Table 1 Legends/Abbreviations Used in Pin Table

Name	Abbreviations	Definitions
Pin type	P	Power supply
	I	Only input
	O	Only output
	I/O	Input/Output
Pin structure	A	Simulation
	D	Digital
	HV	HP

Table 2 GURC01 Pin Functional Description

No.	Name	Pin type	Pin structure	Description
1	VSUP	P	-	Supply voltage
2	TR	IO	HV_A	Communication interface
3	VSSD	P	-	Digital ground
4	VDDD	O	A	Internal digital power supply voltage
5	TIN	I	A	JTAG test input, which should be connected to PCB-GND in application

No.	Name	Pin type	Pin structure	Description
6	TDO	O	D	JTAG data output, which should be connected to PCB-GND in application
7	TDI	I	D	JTAG data input, which should be connected to PCB-GND in the application
8	TCLK	I	D	JTAG clock, which should be connected to PCB-GND in application
9	TMS	I	D	JTAG test mode selection, which should be connected to PCB-GND in application
10	TMEN	I	D	Test mode enable, which should be connected to PCB-GND in application
11	NC	-	-	Failed to connect to the device, which should be connected to PCB-GND
12	INP	I	A	Positive signal input
13	INN	I	A	Negative signal input
14	VSSA	P	-	Analog ground
15	VDDA	O	A	Internal analog power supply voltage
16	DRV2	O	HV_A	Driver output 2
17	GNDP	P	-	Power ground
18	DRV1	O	HV_A	Driver output 1
19	DRVC	O	HV_A	Transformer center tap
20	VT	P	-	Transformer power supply voltage
21	EPAD	P	-	Exposed chip bonding pad, which must be connected to PCB-GND

3 Functional Description

GURC01 is an ultrasonic sensor driver chip, which is used to drive the ultrasonic sensor to generate ultrasonic wave, receive and process echo signal, and realize the function of object distance detection. It is mainly used in ultrasonic parking assist system (USPA, PAS, etc.) and industrial distance measurement.

The chip is mainly composed of the memory, clock, power supply, sensor driver, receiver, signal processor and communication interface. This chapter mainly introduces the system architecture of GURC01 series products and the functions of each module.

3.1 Overview

3.1.1 Principle of ultrasonic distance measurement

Ultrasonic distance measurement is to detect the distance between objects by generating and receiving ultrasonic waves.

The sensor generates an ultrasonic pulse, which will be reflected and received when an object is detected. The distance S between the sensor and the object, the time duration between the sensor generating and receiving the ultrasonic wave is t, v is the velocity of sound ($v=343\text{m/s}$), and the distance S can be obtained by the following formula:

$$S = v * t / 2$$

3.1.2 Measurement period

Perform an ultrasonic ranging operation cycle using IC as follows:

(1) Measurement of noise

The ambient noise is measured Automatically. Compare the measured noise level with the threshold value, and the measurement information is transmitted to the ECU after the measurement.

(2) Generate wave signal

The ultrasonic measurement cycle starts the measurement using the SND (send) or REC (receive) command.

(3) Sample envelope data

The sensor generates the wave signal and sends it out. When an object is detected, the signal will be reflected back. The reflected pulse is compared with the programmable threshold or automatic threshold after amplifying by the receiver, analog-to-digital conversion and signal processing.

(4) Detection of obstacles

If the echo pulse exceeds the set threshold, the TR line will be pulled down and the signal will be transmitted to the control unit. The time from transmitting the pulse signal to receiving the pulse signal can be calculated, and it is proportional to the distance from the object.

(5) ECU receives diagnostic information

The abnormal state during communication is transmitted to ECU.

Once an ultrasonic measurement cycle is started, it cannot be interrupted. If no measurement is performed, it will be idle.

3.2 System architecture block diagram

Figure 2 GURC01 System Architecture Block Diagram

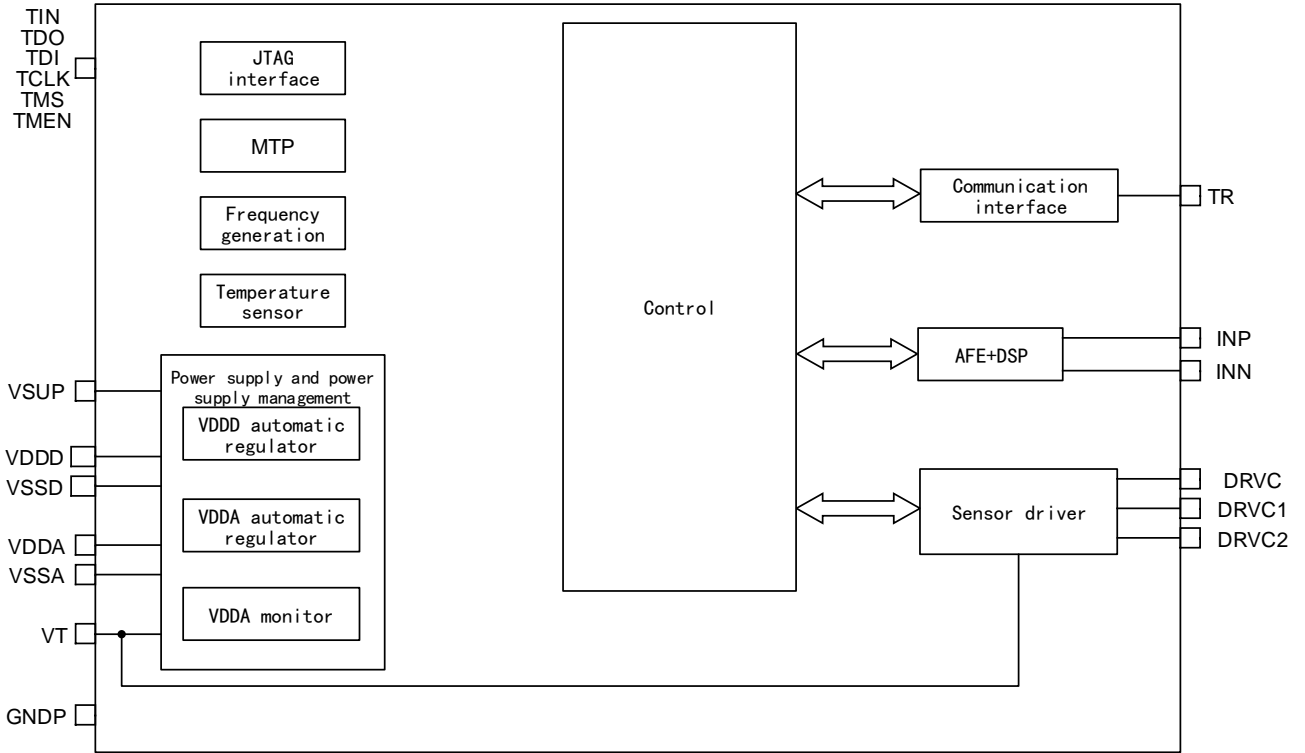

4 Electrical characteristics

4.1 Test conditions of electrical characteristics

All time values are based on the typical values of the typical oscillator frequency f_{osc} . All voltages refer to GNDP. The current flowing into the terminal is positive, while the current flowing out from the terminal is negative.

4.1.1 Maximum and minimum values

Unless otherwise stated, the maximum and minimum values are based on the operating conditions of $V_{SUP} = +6V$ to $+18V$ and $T_A = -40^{\circ}C$ to $+105^{\circ}C$.

4.1.2 Typical value

Unless otherwise stated, the typical values are based on the operating conditions of $V_{SUP}=12V$ and $T_A=+25^{\circ}C$.

4.2 Recommended operating conditions

Table 3 Recommended Operating Conditions

Symbol	Parameter	Minimum value	Maximum value	Unit
f_{DRV}	Frequency of sensor driver	38	72	kHz
V_{SUP}	Supply voltage	6	18	
V_{INP}/V_{INN}	DC input voltage of pins INP and INN	-1.0	1.0	V
I_{INP}/I_{INN}	Current of input pins INP and INN	-20	20	mA

4.3 Absolute maximum rated value

The stress exceeding the following absolute maximum ratings may cause permanent damage to the equipment. They are only pressure ratings; not implying that the equipment operates under these conditions or any other conditions other than those listed in the operation part of this document. Reliability of the equipment may be affected if it is exposed to the absolute maximum rated conditions for a long time.

4.3.1 Maximum temperature characteristics

Table 4 Maximum Temperature Characteristics

Symbol	Condition	Description	Value	Unit
T_A	-	Ambient temperature	-40~+105	°C
T_J	-	Junction temperature	-40~+125	

Symbol	Condition	Description	Value	Unit
T _{STG, welded}	No tape, welded to PCB	Welding storage temperature	-55~+125	
T _{STG, unwelded}	Unwelded	Unwelded storage temperature in the tape	-40~35	

4.3.2 Maximum rated voltage characteristics

Table 5 Maximum Rated Voltage Characteristics

Symbol	Condition	Description	Minimum value	Maximum value	Unit
V _{SUP}	-	Supply voltage	-0.3	36	V
V _{SUP}	t<500ms	Supply voltage	-0.3	40	
V _{TR}	-	Voltage of pin TR	-0.3	36	
V _{TR}	t<500ms	Voltage of pin TR	-0.3	40	
V _D	-	Voltage of pins TIN, TDO, TDI, TCLK, TMS and TMEN	4.5	5.5	
V _{INP/VINN}	-	Voltage of pins INP and INN	-1.5	1.5	
V _{DDD}	-	Internal digital power supply voltage	4.5	5.5	
V _{DDA}	-	Internal analog power supply voltage	3.1	3.5	
V _{DRV1, DRV2, DRVC, VT}	-	Voltage of pins DRV1, DRV2, DRVC and VT	-0.3	40	

4.3.3 ESD protection

Table 6 ESD Characteristics

Symbol	Parameter	Condition	Maximum value	Unit
V _{ESD(HBM)}	Pins VSUP and TR	Test as per AEC-Q100-002 (HBM) chip level	TBD	kV
	Other pins		TBD	kV
V _{ESD(CDM)}	Pin near the corner (Pins 1, 5, 6, 10, 11, 15, 16, and 20)	Test as per AEC-Q100-011 (CDM) chip level	TBD	V
	Other pins		TBD	V

4.3.4 Static latch-up

Table 7 Static Latch Characteristics

Symbol	Parameter	Condition	Type
LU	Static latch-up	T _A =+25°C/105°C, according to JEDEC standard JESD 78	TBD

5 Typical application

5.1 Typical application circuit

ECU and ultrasonic module are connected by three wires, namely GND, VSUP and DATA.

Figure 3 Typical Circuit of GURC01

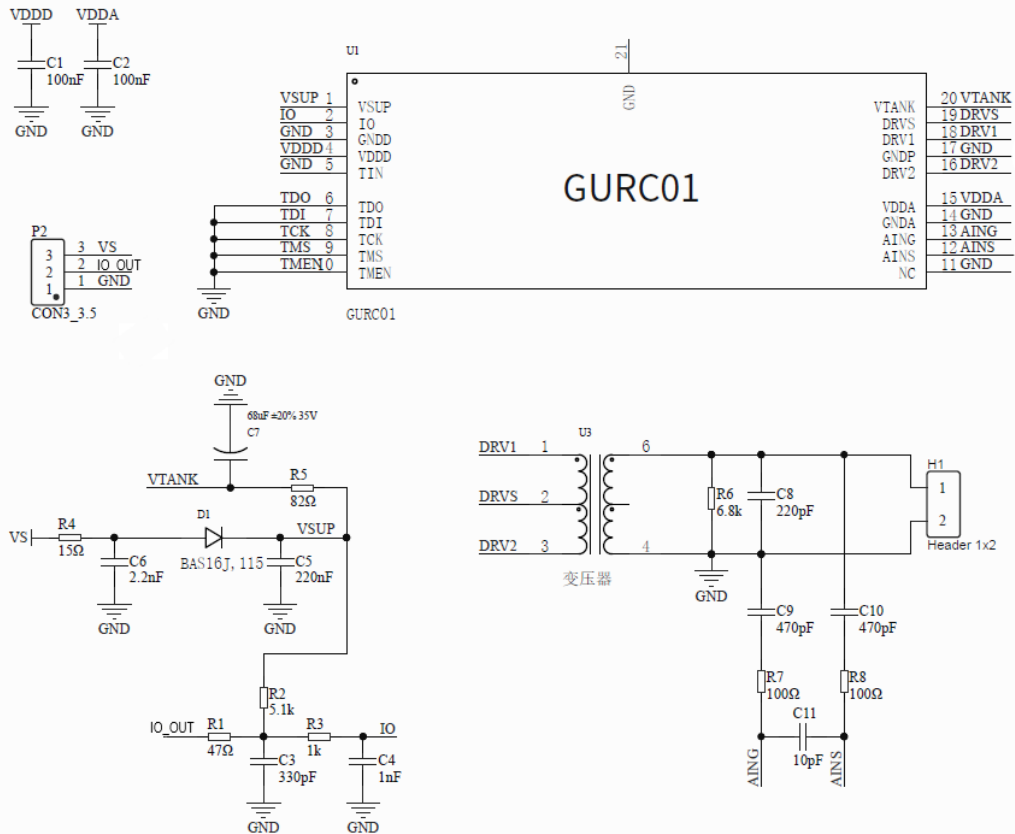

6 Reflow soldering profile information

Figure 4 Reflow soldering profile information

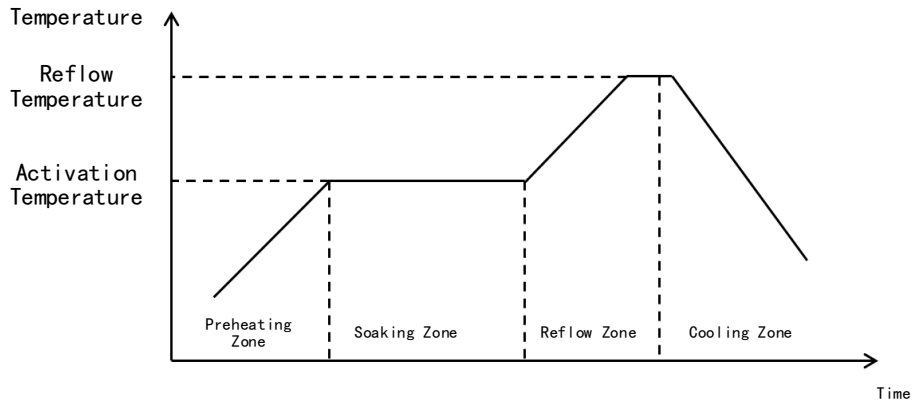

- (1) The recommended heating rate in the preheating zone is 1~3°C/s.
- (2) The soaking zone duration is recommended to be 60~90s, with activation temperature suggested between 80~160°C.
- (3) The reflow zone duration is recommended to be 30~60s, with a heating rate of 3°C/s, and the peak temperature should not exceed 260°C.
- (4) The cooling zone cooling rate is recommended to be around 4°C/s.
- (5) Specific temperature profile settings should be adjusted according to the solder paste type used and the actual SMT environment. The above guidelines are for reference only.

7 Package information

Figure 5 QFN20 Encapsulation Diagram

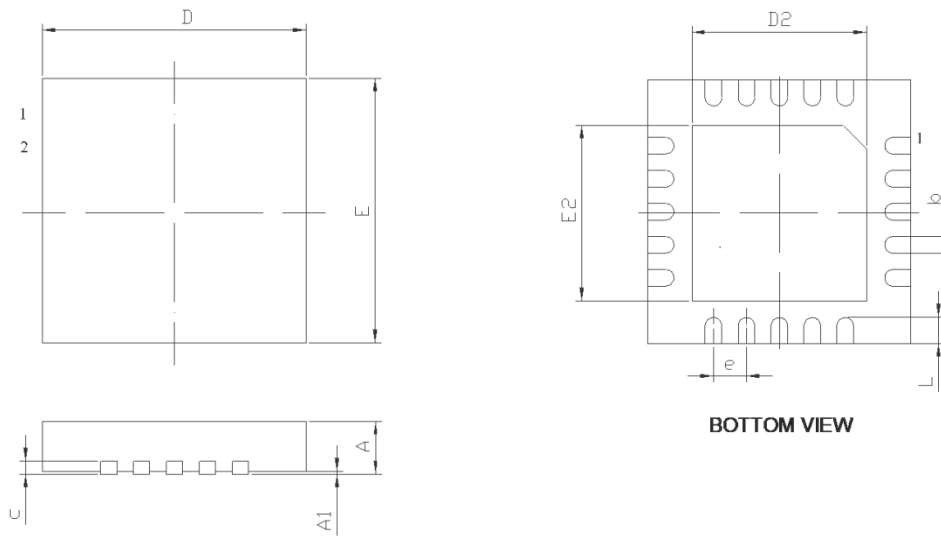

Note: Based on JEDEC standards JESD-51-2 (Still Air), JESD-51-5 (Exposed Pad Soldered to PCB with Thermal Vias), and JESD-51-7 (4-Layer PCB), the typical thermal resistance junction to ambient, $R_{th,ja}$ is 55°C/W.

Table 8 Encapsulation Data

SYMBOL	MILLIMETER		
	MIN	NOM	MAX
A	0.70	0.75	0.80
A1	-	0.02	0.05
b	0.18	0.25	0.30
c	0.18	0.20	0.25
D	3.90	4.00	4.10
D2	2.55	2.65	2.75
e	0.50		
E	3.90	4.00	4.10
E2	2.55	2.65	2.75
L	0.35	0.40	0.45

Note: The mm value is valid, and the inch value includes round-off error.

Figure 6 QFN20-4 x4 Recommended Welding Layout

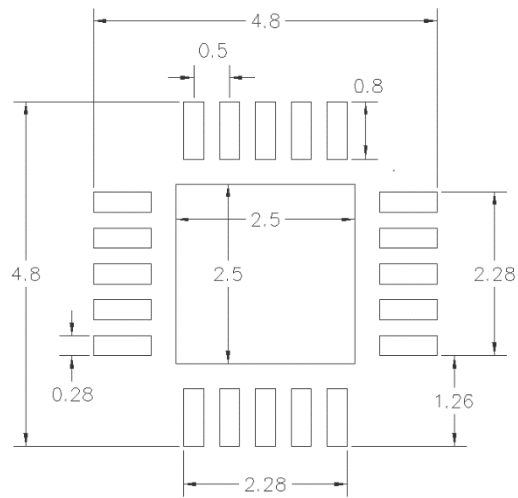
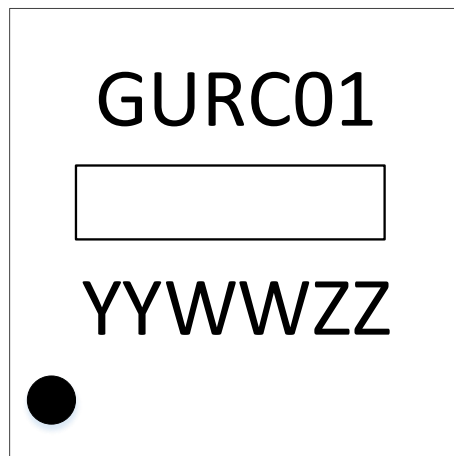

Figure 7 Identification Diagram

Product model



YYWW: Year and week number
ZZ: Version number

8 Packaging information

8.1 Tray packaging

Figure 8 Tray Packaging Diagram

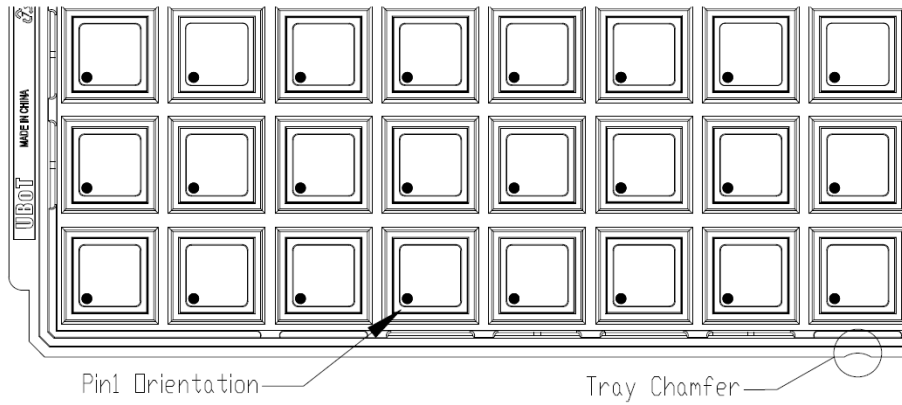

Tray Dimensions

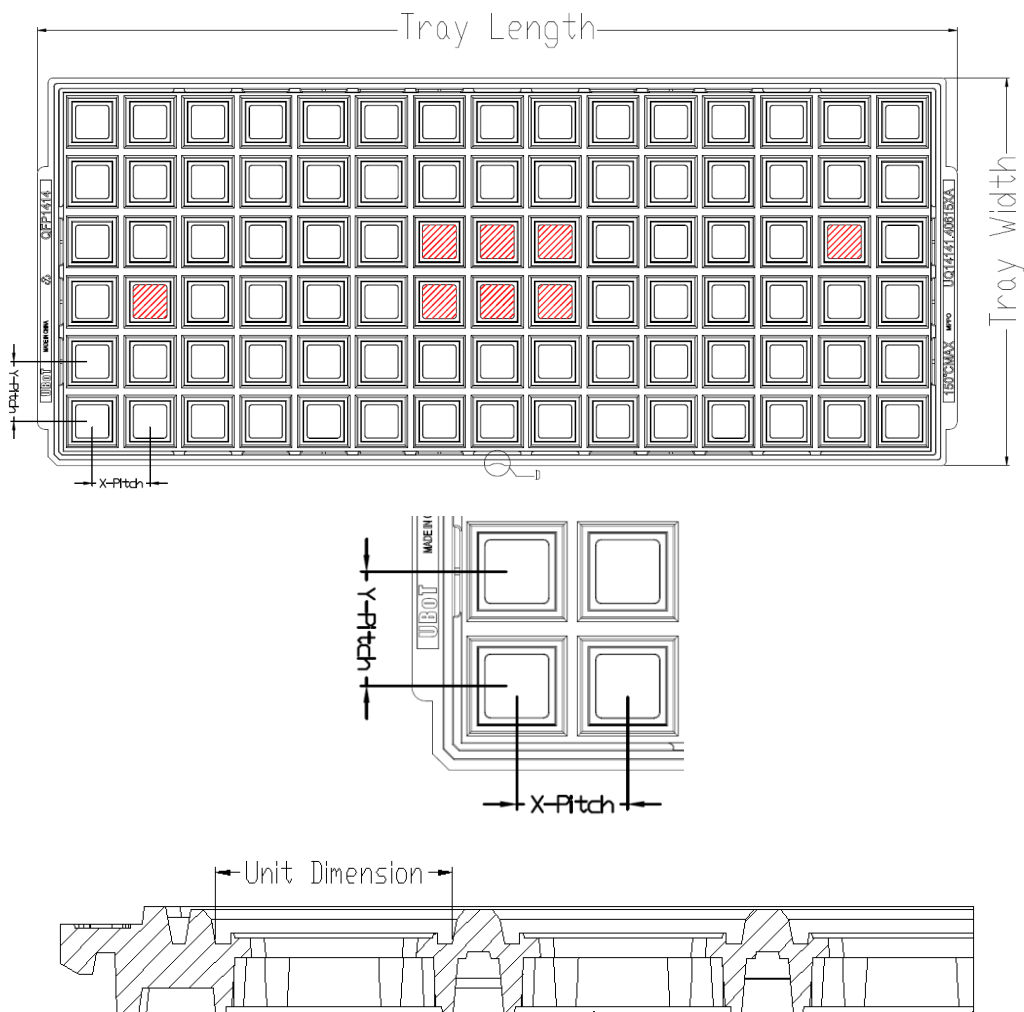

All photos are for reference only, and the appearance is subject to the product

Table 9 Tray packaging parameter specification

Device	PKG Type	Pins	SPQ	X-Dimension	Y-Dimension	X-Pitch	Y-Pitch	Tray Length	Tray Width
GURC01	QFN	20	4900	4.2	4.2	8.8	9.2	322.6	135.9

8.2 Reel packaging

Figure 9 Reel Dimensions

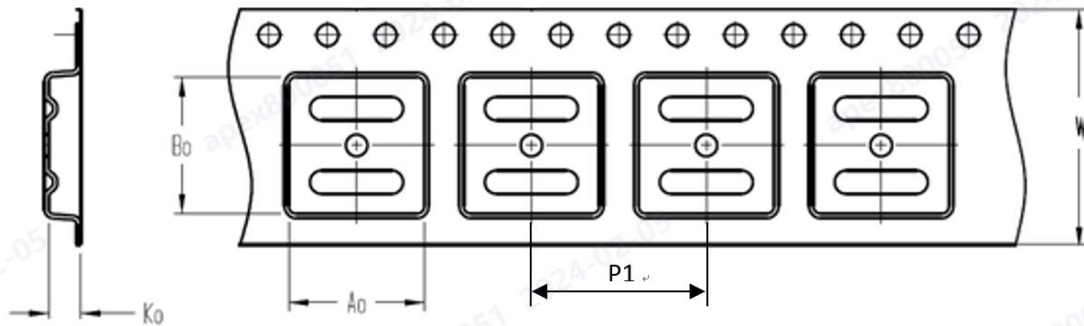

A0	Dimension designed to accommodate the component width
B0	Dimension designed to accommodate the component length
K0	Dimension designed to accommodate the component thickness
P1	Dimension designed to accommodate the component pitch
W	Overall width of the carrier tape

Figure 10 Quadrant allocation in PIN1 direction in tape

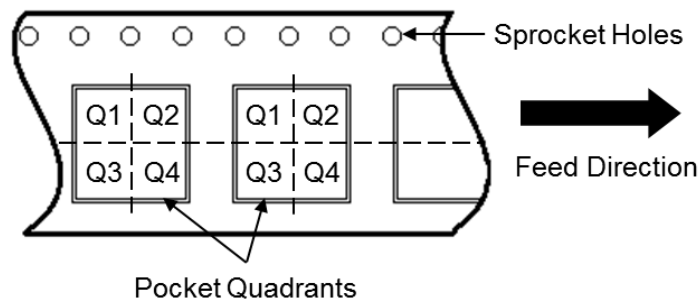

Figure 11 Reel Dimensions

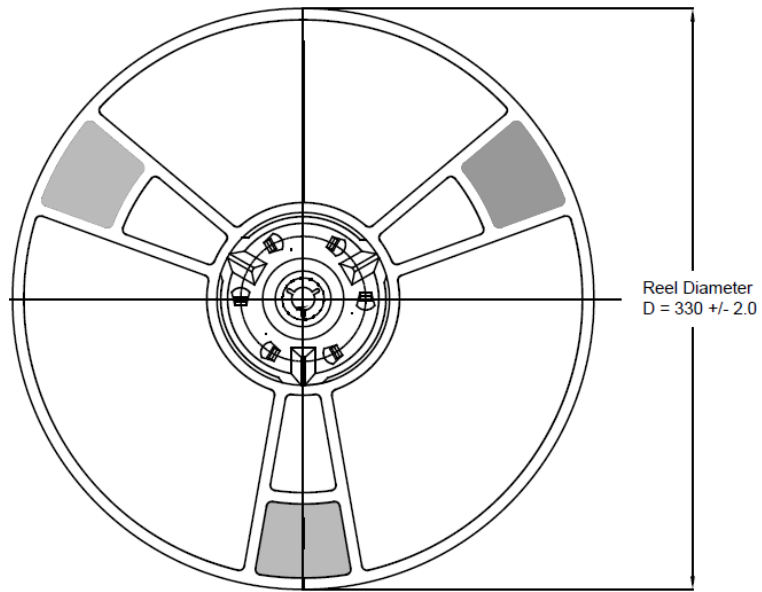

Table 10 Tape packaging parameter specification

Device	Package Type	Pins	SPQ	Reel Diameter (mm)	A0 (mm)	B0 (mm)	P1 (mm)	K0 (mm)	W (mm)	Pin1 Quadrant
GURC01-R	QFN	20	5000	330	4.3	4.3	1.1	8	12	Q1

9 Ordering information

Table 11 Ordering Information Table

Order Code	Interface	Package	Packaging	SPQ	Temperature range
GURC01	3 wires	QFN20	Tray	4900	-40°C to +105°C
GURC01-R	3 wires	QFN20	Reel	5000	-40°C to +105°C